

## DIESEL UNITS

### STANDARD FEATURES

#### 1 UNx™ FLUID END

- proven field performance since 1987
- the most advanced pump on the market
- the heart of the Jetstream waterblast system

#### 2 SAFETY FEATURES

- complete rupture disc assembly as standard
- relief valve assembly as standard
- designed to protect operator and pump from over-pressurization
- hydraulic throttle control reduces engine and pump speed to idle when unit is not in operation

#### 3 STRONG POWER FRAME

- strongest in the industry
- made of ductile iron
- largest bearings of any pump on the market
- crank made of heat treated billet steel

#### 4 ATMOSPHERIC WATER TANKS

- for use with all water supply conditions
- 1/4 inch hot-dip galvanized steel

#### 5 HIGH PERFORMANCE ENGINES

- Cummins, John Deere or Caterpillar

#### 6 STATE-OF-THE-ART CONTROLS

- Jetstream's hydraulic throttle control for easy, accurate engine speed control
- tachometer
- oil pressure
- fuel meter
- amp meter

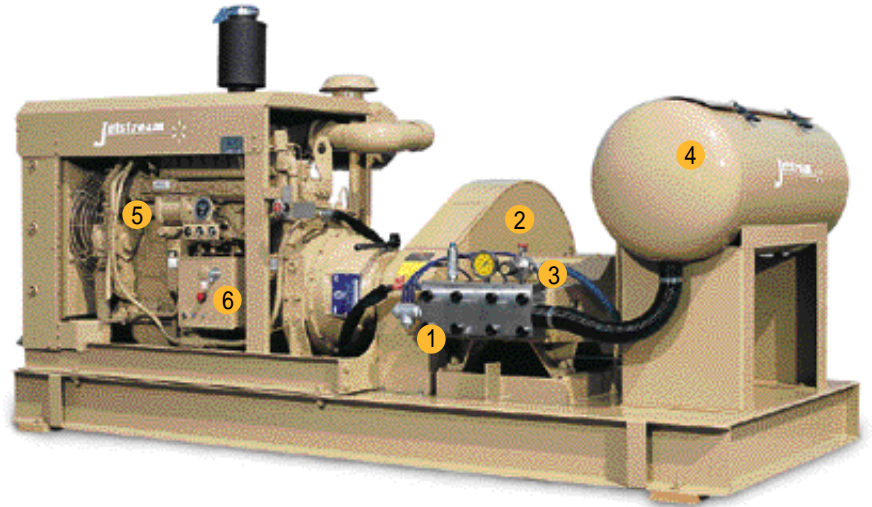

## Every Jetstream UNx™ pump offers you . . .



#### SERVICEABILITY

- packing change within five minutes
- pop-out cartridge valve change in 15 minutes
- no special tools or equipment required

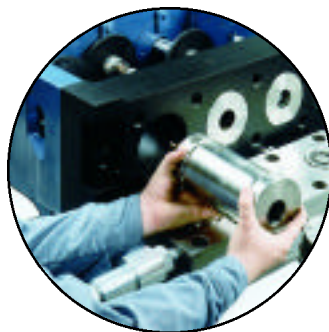

#### SIMPLICITY

- only 37 total parts
- UNi-Valve one-piece cartridges include suction & discharge valves, seats, springs & seals
- swing-down manifold for easy access to components

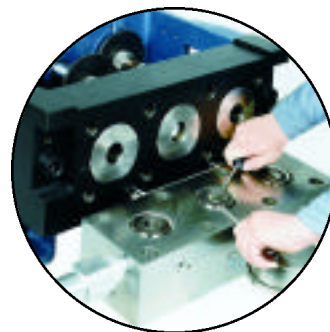

Serviceability  
Simplicity  
Versatility

#### VERSATILITY

- pressure range conversion on the job
- change operating pressure from 6,000 psi to 40,000 psi
- bolt on fluid ends available for most waterblast pump brands

# OPTIONS

4-Wheel Tandem Trailer



4-Wheel Steerable Trailer



Goose Neck Trailer

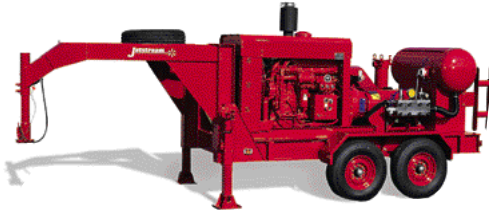

## Trailer options

- Tandem trailer fenders
- Electric tandem or hydraulic tandem trailer brakes
- ICC tandem trailer lighting
- Lifting bail

## Accessories

- Safety watch shutdown system
- 6,000-40,000 psi conversion kits
- Multi-gun valves
- By-pass valve
- Regulatory valve, shut-in system
- DuraSafe-control gun (hand or foot)
- TWIS-LOK, quick disconnect
- Safety lances and hoses
- Spinning nozzles tube/surface
- Abrasive induction system
- Safety apparel



## 1 Filter Package

- low and high pressure water filters
- protects from damaging contaminants
- available in stainless steel or hot-dipped galvanized

## 2 Conversion Storage Box

- stores complete fluid end conversion kit
- carry tools and supplies needed on jobs

## 3 Hose Racks

- for storage and transport
- fits up to 200' hose length
- durable and long lasting

## 4 Work Bench and Vise

- dimensions: 2.5' X 5'
- heavy-duty work bench for operator's convenience
- industrial strength vise

Jetstream of Houston Inc.  
4930 Cranswick Houston, TX 77041-7724  
Phone: 713-462-7000  
Fax: 713-462-5387  
www.waterblast.com

**Jetstream** 

**ENVIRONMENTAL  
PRODUCTS  
GROUP**

**Call the Waterblast Superstore**

**800-231-8192**

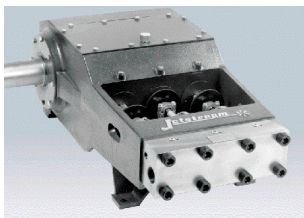



# Advanced Waterblasting System

## DIESEL UNITS

### SPECIFICATIONS

Weight  
(without options)

	Pressure (psi)	6,000	7,500	10,000	12,000	15,000	20,000	30,000	40,000		
<b>3000 Series</b>	<b>110 HP</b>	Pressure (psi)	6,000	7,500	10,000	12,000	15,000	20,000	30,000	40,000	
	Plunger No.	11	10	9	8	7	6	-	-	Trailer: 4,100 lbs.	
	Flow (GPM)	23.2	18.4	14.9	11.8	9.9	7.4	-	-	Skid: 3,710 lbs.	
<b>3000 Series</b>	<b>125 HP</b>	Pressure (psi)	6,000	7,500	10,000	12,000	15,000	20,000	30,000	40,000	
	Plunger No.	-	11	10	9	8	7	-	-	Trailer: 4,200 lbs.	
	Flow (GPM)	-	23.2	18.4	14.9	11.8	9.0	-	-	Skid: 3,810 lbs.	
<b>3600 Series</b>	<b>152 HP</b>	Pressure (psi)	5,000	7,000	10,000	12,000	15,000	20,000	30,000	40,000	
	Plunger No.	15	13	11	10	9	8	-	-	Trailer: 6,400 lbs.	
	Flow (GPM)	43.6	32.6	23.5	19.4	15.7	11.8	-	-	Skid: 5,930 lbs.	
<b>3600 Series</b>	<b>174 HP</b>	Pressure (psi)	6,000	7,500	10,000	12,000	15,000	20,000	30,000	40,000	
	Plunger No.	15	13	12	11	10	8	7	6	Trailer: 6,500 lbs.	
	Flow (GPM)	43.6	34.6	27.8	22.5	18.3	12.4	8.2	6.7	Skid: 6,030 lbs.	
<b>4200 Series</b>	<b>215 HP</b>	Pressure (psi)	6,000	8,000	10,000	12,500	15,000	20,000	30,000	40,000	
	Plunger No.	15	13	12	11	10	8	7	6	Trailer: 7,950 lbs.	
	Flow (GPM)	48.7	38.6	31.2	26.2	20.8	14.3	9.7	7.8	Skid: 7,300 lbs.	
<b>4200 Series</b>	<b>260 HP</b>	Pressure (psi)	6,000	8,000	10,000	12,500	15,000	20,000	30,000	40,000	
	Plunger No.	16	15	13	12	11	9	8	7	Trailer: 8,032 lbs.	
	Flow (GPM)	60.4	48.7	38.6	31.2	26.1	17.5	11.5	9.7	Skid: 7,385 lbs.	
<b>4200 Series</b>	<b>300 HP</b>	Pressure (psi)	6,000	7,500	10,000	12,000	15,000	20,000	30,000	40,000	
	Plunger No.	-	16	15	13	12	10	-	8	Trailer: 9,450 lbs.	
	Flow (GPM)	-	60.4	48.1	38.9	31.2	21.4	-	11.5	Skid: 8,560 lbs.	

### DIMENSIONAL DRAWINGS

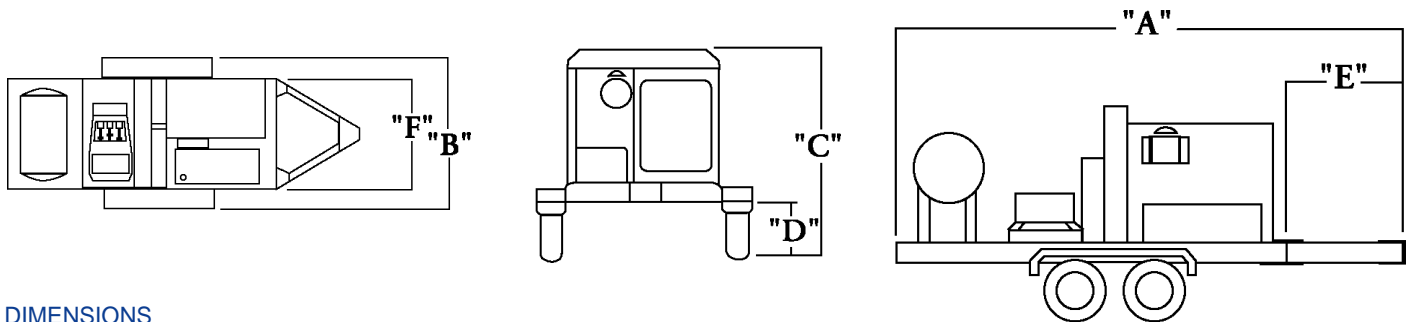

### DIMENSIONS

	3000 Series	3600 Series	4200 Series	(300 HP)
A:	12'4"	13'10"	15'11"	17'6"
B:	5'11"	6'9"	7'3"	7'10"
C:	6'5"	6'9"	7'4"	9'4"
D:	19.5"	19.5"	19.5"	21.5"
E:	34.125"	42.875"	47.75"	52.75"
F:	48.5"	58.5"	64.75"	71.75"

Jetstream of Houston Inc.  
4930 Cranswick Houston, TX 77041-7724  
Phone: 713-462-7000  
Fax: 713-462-5387  
www.waterblast.com



Call the Waterblast Superstore

800-231-8192

